

CAD FILE:

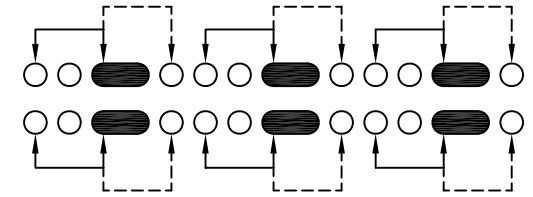

SCHEMATIC (NON-SHORTING)

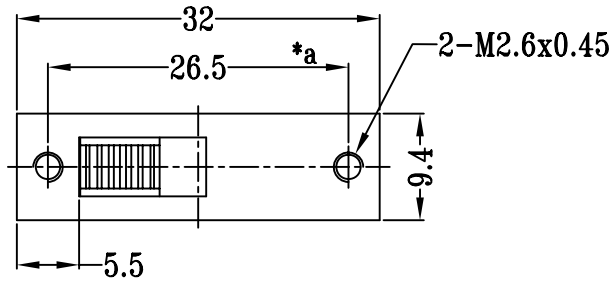
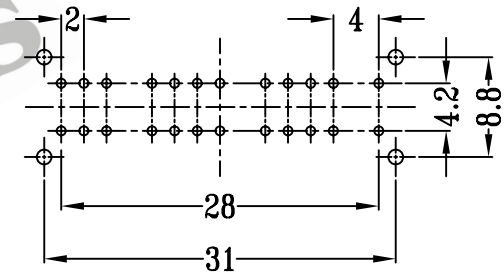
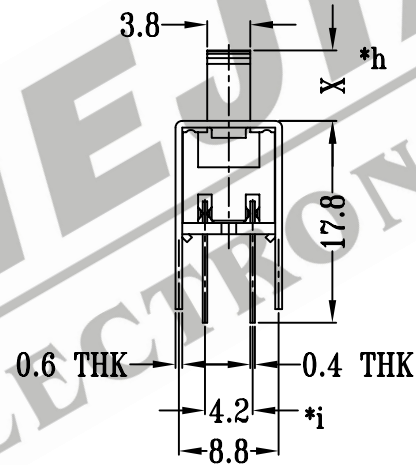
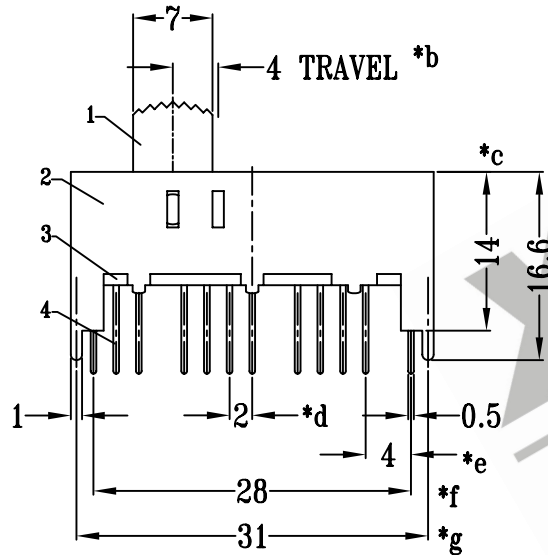

P.C.B LAYOUT

注:带"*"表示关键尺寸(9个)

NO.	PART NAME	MATERIAL	Q'TY	FINISHING	TOLERANCE UNLESS SPECIFIED	SHENZHEN XIEJIA ELECTRONICS CO.,LTD.						
8						ISSUE		DATE		DESCRIPTIONS	APPD.	
7	STEEL BALL	STEEL	2	NATURAL	WITHIN : 1.5±0.1mm	TITLE : VERTICAL SLIDE SWITCH				UNIT : MM	DRWG NO.: XJ-DR-SS62H03-00	
6	SPRING	STEEL WIRE	1	TEMPER	OVER : 1.5±0.2mm					SCALE: 3 : 2	DWN.	ZHOUYU
5	CONTACT CLIP	PBS STRIP	6	Ag PLATED		MODEL: SS-62H03				CHK'D	FANGYING	2003-12-7
4	TERMINAL	BRASS STRIP	24	Ag PLATED OVER Ni PLATED						APPD.	KANGXINAN	2003-12-7
3	BASE	PHENOLIC RESIN	1	NATURAL		ALL MATERIALS MUST BE COMPLIANT TO ROHS						
2	FRAME	STEEL STRIP	1	Ni PLATED								
1	KNOB	POM	1	BLACK								